





 **Safari pilot<sup>3</sup>**

**TANDEM PILOT WITH SPLIT LEGS**

Whilst Gin Gliders has made every effort at the time of publication to provide accurate information, product specifications are subject to change without notice and may vary from those shown.

# CONTENTS

Safari pilot 3

Thank You.....	4	Maintenance and repairs.....	25
Warning.....	5	Final words.....	28
Introducing the Safari pilot 3.....	6	Harness diagram.....	32
Specifications.....	7		
Components of the Safari pilot 3.....	8		
Before you fly.....	10		
Back protector installation.....	11		
Maintaining the back protector.....	12		
Rescue installation.....	14		
Rescue handle installation.....	15		
Rescue bridle installation.....	16		
Storage.....	20		
Adjustments.....	21		
Flying with the Safari pilot 3.....	22		

# THANK YOU

**For choosing Gin Gliders. We are confident you'll enjoy many rewarding experiences in the air with your new GIN harness.**

This manual contains important safety, performance and maintenance information.

Read it before your first flight, keep it for reference, and please pass it on to the new owner if you ever re-sell your harness.

Any updates to this manual, or relevant safety information, will be published on our website: [www.gingliders.com](http://www.gingliders.com). You can also register for e-mail updates via our website.

Happy flying and safe landings,  
GIN Team



## **WARNING**

Like any extreme sport, paragliding involves unpredictable risks which may lead to injury or death. By choosing to fly, you assume the sole responsibility for those risks. You can minimize the risks by having the appropriate attitude, training and experience and by properly understanding, using and maintaining your equipment. Always seek to expand your knowledge and to develop self-reliance. If there is anything you do not understand, consult with your local dealer as a first point of contact, with the GIN importer in your country or with Gin Gliders directly.

Because it is impossible to anticipate every situation or condition that can occur while paragliding, this manual makes no representation about the safe use of the paragliding equipment under all conditions. Neither Gin Gliders nor the seller of GIN equipment can guarantee, or be held responsible for, the safety of yourself or anyone else.

Many countries have specific regulations or laws regarding paragliding activity. It's your responsibility to know and observe the regulations of the region where you fly.

**INTENDED USE:** *Lightweight air sports equipment with a maximum mass of less than 120kg, operated in the paragliding division.*

# INTRODUCING THE SAFARI PILOT<sup>3</sup>

The Safari Pilot 3 is designed to offer the highest level of comfort and easiness for professional daily use.

It's a split-leg harness that's compact, light, durable and super comfortable in flight. It's also packed full of safety features.

We put a lot of effort into finding the best pilot position in terms of piloting efficacy, balance and stability of the pilot/passenger unit. The "lay front" position offers great control and visibility, but is still inclined sufficiently to offer great support.

The harness offers first class support of the whole of the back — there are no pressure points. The result is no back pain even working all day, everyday. The adjustments are carefully thought out, and have been purposefully limited to preserve the comfort and stability of the harness.

Despite being a fully featured working tool, the Safari pilot 3 is still compact and easy to pack, thanks to the design and material choices. It also packs especially well with the Safari passenger 3.



# SPECIFICATIONS

Size	ONE SIZE
Pilot height (cm)	170 - 190
Rescue volume (L)	11.0
Carabiner distance (cm)	44
Seat width (cm)	55
Seat length (cm)	40
Back pocket volume (L)	18
Protector pocket volume (L)	24
Rescue bridle length (mm)	1790 * 2

\* Delivered with rescue handle and rescue bridles

## CERTIFICATION

The Safari pilot 3 is **EN** and **LTF** certified, max load 120 daN

Certification number: **PH\_444.2024** | **CE** certification

## DELIVERY PACKAGE

- 1 Harness
- 1 Rescue deployment handles
- 2 Rescue bridles
- 2 GIN 30mm carabiners
- 1 Gopro Pocket

## BACK PROTECTION

- Aerobean protector
- 22cm back protection
- CE and EN Certified

## HARNESS COMPONENT WEIGHTS

COMPONENTS	One size
Rescue handle (kg)	0.04
Gopro pocket (kg)	0.100
Aerobean protector (kg)	0.300 - 0.350
30mm carabiner 2 pieces (kg)	0.065
Harness weight (kg)	2.8

# COMPONENTS OF THE SAFARI PILOT<sup>3</sup>

## 1 BACK PROTECTION

The Safari pilot 3 comes with the Aerobean protector. The protection must be inspected after any impact and assessed for damage. The protector protects the pilot as much as possible in the event of an incident, but it cannot completely eliminate the risk of injury. The Safari pilot 3 back protection is EN and CE certified.

## 2 GIN CARABINERS

Included with your harness is a pair of GIN 30mm carabiners. The Safari pilot 3 is compatible with quick release carabiners but on the main connection (Spreader bar or supple spreaders). Automatic aluminium carabiners have a limited lifetime due to metal fatigue. They must be replaced after 5 years or 500 flight hours, whichever is soonest. They should never be used between spreaders and tandem wing risers as main carabiners. They should also never be used to connect bridles to the reserve.

## 3 GOPRO POCKET

Included with the Safari pilot 3 harness is a custom designed gopro pocket, which is designed to storage any action camera for the take off, landing, or any other flying situation.

The gopro pocket has been designed to provide easy access for the pilot to the action camera. It is easily removable and it can be installed in either left or right side position.

## 4 RESCUE BRIDLES (2)

Included with your harness is a pair of 1790 mm rescue bridles.

There is also a rescue bridle zip tunnel to cover them, please attach them to your rescue riser following the instructions shown on page 16

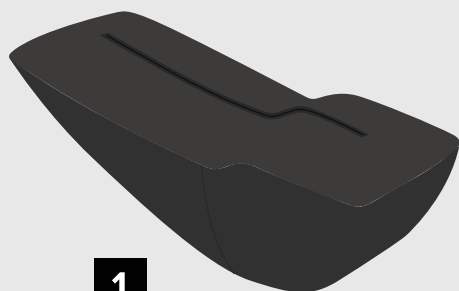

# COMPONENTS OF THE SAFARI PILOT<sup>3</sup>

## 5 RESCUE DEPLOYMENT HANDLE

The Safari pilot 3 comes with a rescue deployment handle. The rescue deployment handle comes with 1 parachord plastic rod to close the rescue container located in the harness. Check the parachord loops before every take off and make sure the rescue container is closed before taking off.

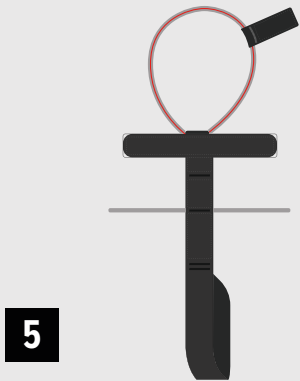

# BEFORE YOU FLY

Make sure your dealer has checked the harness for completeness and basic settings. Your harness must be assembled by a suitably qualified paragliding professional, for example, your instructor.

Gin Gliders recommends that assembly be carried out in the following order. If you are in any doubt whatsoever about this procedure, please seek professional advice from your instructor, GIN dealer or importer.

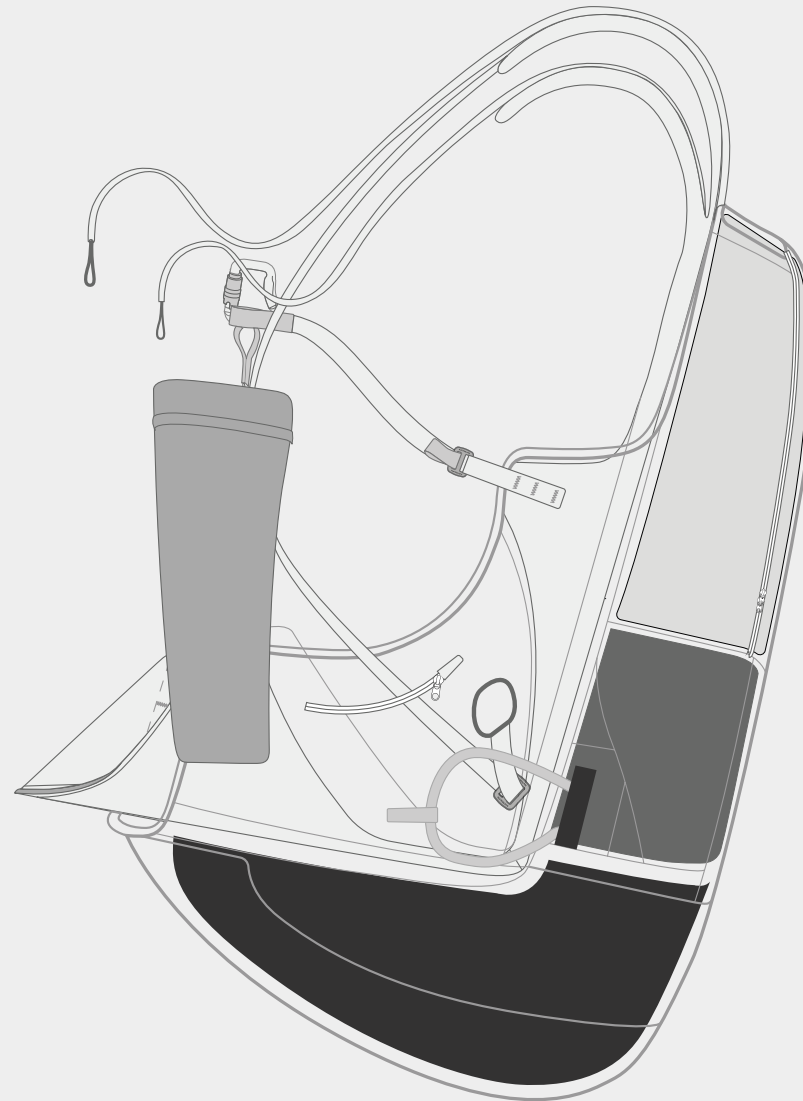

## INSTALLING THE BACK PROTECTOR

To install the back protector in the Safari pilot 3, first open the zipper compartment under the seat. Insert the back protector narrow end first. Guide the back protector into the correct position making sure that the narrow top piece properly sits between the back support and the rescue container. The back protector should fit snugly into the container. Once you are sure the protector is installed correctly, close the protector compartment zipper.

**! WARNING:** *The back protection does not eliminate the chance of injury as a result of a crash.*

**! WARNING:** *If the back protection zip is not fully closed, the protector will not work effectively*



## PROTECTION | *Aerobean*

The advantage of the Aerobean back protection is the increased safety rating compared to other technologies.

Also the packing volume is reduced and the harness is lighter compared to a conventional foam protector. The Aerobean protector allows lower thickness maintaining the same test results than a conventional foam protector.

On takeoff the harness offers full protection, which is one of the best features of this protector. In the event of an incident the back protection will help to dissipate the force of the impact. However, the back protection cannot completely eliminate the risk of injury to the pilot.

## MAINTAINING THE BACK PROTECTOR

We recommend that you inspect your back protection periodically to make sure the zipper holding the beans in place remains closed and the outer fabric is in good condition. We recommend that you do not fly with a back protector that shows signs of damage.

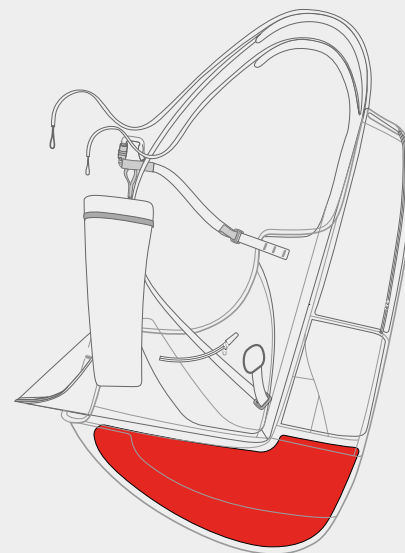

**! WARNING:** *The back protection does not eliminate the chance of injury as a result of a crash.*

**! WARNING:** *If the harness is subjected to temperatures exceeding 70 degrees Celsius the integrity of the back protection may be compromised.*

**! WARNING:** *After any strong impact the back protection should be professional inspected for external or internal damage. Any damage can decrease the effectiveness of the back protection.*

## PROTECTOR SIZE

Size and dimensions of the Aerobean protector.

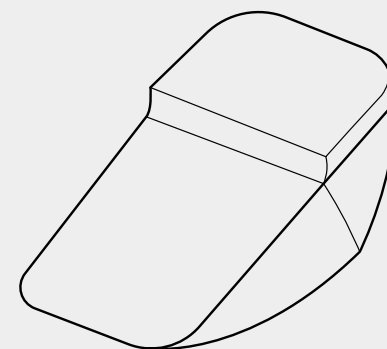
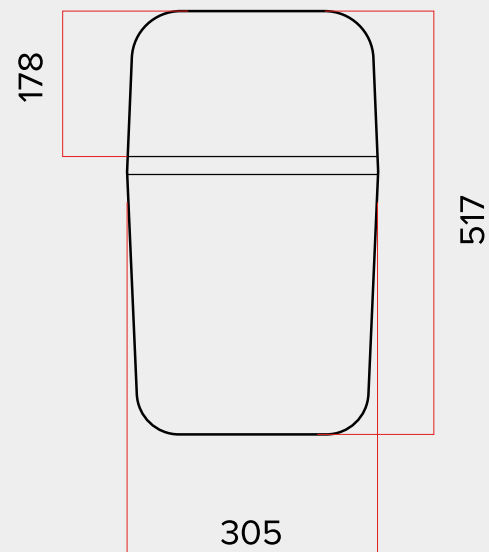
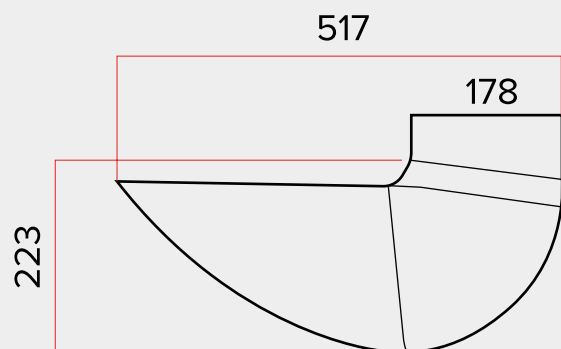

# RESCUE INSTALLATION

## RESCUE INSTALLATION AND COMPATIBILITY CHECK

Gin Gliders recommend that rescue installation is performed properly by a competent person. The rescue parachute is a pilot's last resort and failure to pack or connect the reserve parachute in the correct way may cause death or severe injury. The pilot is responsible for ensuring proper installation.

This harness is compatible with the Yeti rescue #50 and #60 rescue parachutes. Other manufacturers' rescues may also be used but we cannot guarantee their function. The pilot is responsible for checking compatibility.

Every first installation of a rescue system into the harness (that means every new combination of harness and rescue system) must be checked by a qualified paragliding professional for compatibility. To verify the installation, you must perform a test deployment by sitting in a simulator.

Rescue parachutes should be repacked at least every 150 days; so installing your rescue in a new harness may also provide a good opportunity for a repack. After every repack of the rescue parachute you should also do a compatibility check.

## RESCUE COMPATIBILITY

**MAKE SURE THAT THE RESCUE PARACHUTE CAN BE RELEASED FROM THE RESCUE CONTAINER**—*it must be done by you, the pilot, sitting in the harness hanging from a simulator.*

## RESCUE DEPLOYMENT

To deploy the rescue; locate the handle, with a firm grip pull the handle towards the pilot and slightly away from the harness to extract the rescue from the harness compartment. In the same motion that pulls the rescue from the compartment swing the rescue by the handle while looking for clear airspace (clear of lines, glider and harness). Release your grip of the handle and allow both handle and rescue to travel through the air extending the rescue lines as it goes. The rescue should come out of the deployment bag and start to inflate once the rescue lines have been extended.

In a negative spin the decent speed of the the pilot and wing is much less than in a spiral situation. Therefore it is very important to throw the rescue away from the pilot with as much power as possible to quickly extend the lines and prevent the rescue from becoming entangled with the paraglider.

For further information on rescue deployment please refer to your rescue manual.



**! WARNING:** *If you are in any doubt about any aspect of rescue installation, seek professional advice!*

**I IMPORTANT:** *You must perform a test deployment from a simulator to verify the installation.*

## ATTACHING THE RESCUE DEPLOYMENT BAG TO THE HARNESS DEPLOYMENT HANDLE

The rescue container for this harness comes with its own deployment handle, which **MUST** be used. This handle and its strap must be connected to the deployment bag of the parachute. In particular, check the length of the strap connecting the rescue deployment handle to the rescue inner container. It should be long enough that the reserve can be extracted without the danger of the pin not being pulled before the strap tightens on the reserve, but not so long that there is excessive slack that extends the movement required for deployment.



## INNER BAG

1



Handle attachment

2



Pass the handle through the center loop

3



Pass the handle through itself

4



Pull to make a clean, tight knot

**IMPORTANT:** Use only the rescue deployment bag supplied with your Safari pilot 3. The use of other rescue deployment bags may cause deployment failure.

## CONNECTING THE RESCUE BRIDLE

To connect a rescue to your harness we recommend using a GIN Rescue Carabiner. If you choose to use different type of connector, it should be rated at least 20 times the maximum weight. For example, our recommended 6mm Stainless Steel screwgate maillon (square) connector has a breaking load in excess of 28kN. It is the pilot's responsibility to check the compatibility of the rescue system and ensure that it is installed properly.

Be sure to inspect your connector during normal maintenance and safety checks. Replace it whenever there are any signs of wear and check your rescue system with a professional after any deployment. We recommend that you cover the connection using the Maillon rapid cover to prevent excess friction. Rubber-bands should also be used to secure the attachment and prevent excess friction.

**Recommended by GIN: 6mm stainless steel screwgate maillon**

**6MM SQUARE MAILLON**  
**BREAKING LOAD: >28KN**

### MAILLON CONNECTION *(RECOMMENDED BY GIN GLIDERS)*



### SPREADER ATTACHMENT POINT

The Safari Pilot 3 comes without any rescue attachment point itself. But it comes with a routing system to protect the bridles and to avoid the rescue bridles to be stuck with any external elements.

The rescue should be attached via maillon to the chosen spreader.

At Gin Gliders, we offer 3 different spreader systems: Spreader bars / supple spreaders / light spreaders.

**⚠ WARNING:** *When connecting the rescue bridle be sure to secure the connection using tape, rubber bands or heat shrink wrap. If the lines are not secure they may burn or cut from excess friction.*

**⚠ IMPORTANT:** *Be sure to connect both rescue bridles to the rescue.*

## CONNECTING THE RESCUE BRIDLE



Connect the rescue bridles to the rescue riser



Route the rescue bridles through the zip bridle tunnel.  
And close the zipper until the end



Close the end velcro to avoid the zip opening



Connect the rescue bridle to the spreader maillon and close it.



Close the velcro panel of the spreader bar



## INSTALLING THE RESCUE



Once the rescue bridle is connected, and the rescue handle is connected to the rescue, open the rescue container



Insert the rescue facing UP on the rescue container



Close the main flap of the rescue container



Partially close the zipper



Insert plastic parachords to avoid friction on the rescue loops



Introduce the paracords by the second flap through the eyelets

## INSTALLING THE RESCUE

1



Pass the rescue handle paracord through the rescue loops

8



Introduce the side webbing of the rescue handle in the fabric cover

9



Close the rescue tunnel zipper until the end

10



Close the top velcro

11



Make sure the side of the velcro is properly closed

# STORAGE

## BACK POCKET (1)

The 30L back pocket is designed to store the pilot's rucksack and other light accessories during flight. To ensure the correct inflation of the harness, the compression strap has to be pulled before flight

## SIDE POCKETS (2)

The side pockets are a smaller pocket that can hold a phone, snacks or other small belongings. They are both easily accessible during flight and have zippers to avoid losing your items during flight. The harness has 2 side pockets, one on each side of the harness.

## GOPRO POCKET(3)

There is a removable GoPro pocket that can be installed on both sides of the harness with an easy velcro system. This pocket has no closing so it is not recommended for the storage of any item that could fall while flying.. The GoPro pocket has a loop to attach your camera or any other belongings.

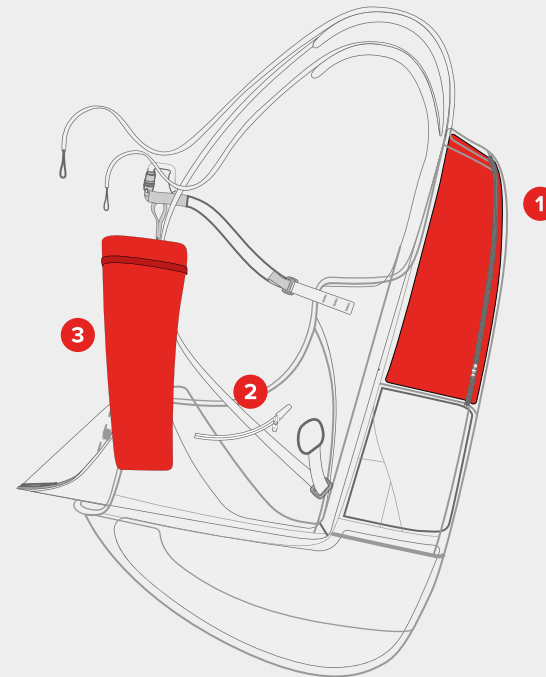

# ADJUSTMENTS

After choosing a harness that is close to your body size, adjust your harness to suit your physique and flying style. It is important to adjust it correctly to ensure you can easily slide into the sitting position after take off. A poorly adjusted harness can adversely affect the flying characteristics of your paraglider.

Perform adjustments before your first flight by hanging in a simulator and fine-tune the settings if necessary during your first few flights.

## SHOULDER STRAPS (1)

On the Safari pilot<sup>3</sup>, the shoulder straps must be adjusted on the hip of the pilot. The optimum setting for the shoulder straps depends on the height of the pilot. Step into the harness and stand upright with the breast strap closed, symmetrically adjust the shoulder straps until they are a snug fit, but not tight.

To tighten: pull forward on the BLACK dotted loop

To loosen: pull forward on the RED loop on the top of the shoulder strap.

## LUMBAR STRAPS (2)

Below the breast straps you will find a buckle to adjust the lumbar strap. To get the back fully supported by all the seat, tighten the strap until the back pressure is distributed evenly.

## BREAST STRAP (3)

After adjusting the shoulder straps, adjust the breast strap in a comfortable position and tighten so there is slight pressure on the shoulder straps.

**NOTE:** Make sure that the rescue system has been installed before making adjustments.



# FLYING WITH THE SAFARI PILOT<sup>3</sup>

## General warnings and advice

Before every flight, check the following:

- ⊙ Are you in good physical and mental condition?
- ⊙ Are you familiar and compliant with all applicable laws and regulations in your area?
- ⊙ Are you within the certified weight range of your paraglider?
- ⊙ Do you have the necessary valid insurance cover (e.g. liability, medical, life)?
- ⊙ Are you briefed thoroughly about the site, airspace and expected weather conditions of the day?
- ⊙ Is your equipment and choice of site suitable for your level of experience?
- ⊙ Do you have a suitable helmet, gloves, boots, eye-wear and adequate clothing?
- ⊙ Are you carrying some form of identification, so that people know who you are in case of an accident?

Take along a radio and mobile phone if possible.

- ⊙ Do you fully understand how to safely use your new equipment? If not, have your instructor or dealer explain anything you are not sure about.

When you go for your first flight on your new harness, be sure to pick a day and site that does not present you with any unfamiliar challenges. During your first flight, familiarize yourself with the in-flight characteristics of your new harness.

## Pre-flight checks

As part of your normal pre-flight check routine, check:

- ⊙ Is there any damage to the harness or carabiners that could affect its airworthiness?
- ⊙ Is the rescue parachute container closed correctly with the pins in the right position?
- ⊙ Is the deployment handle correctly inserted or attached?
- ⊙ Are all buckles, belts, zips securely fastened? Buckles should click into place as you close them, and a gentle pull on the fastened buckle verifies this. Secure any zips after fastening the buckles. Take extra care in snowy or sandy environments.
- ⊙ Is the paraglider connected correctly to the harness with both carabiners secured by their locking mechanisms?
- ⊙ Are all pockets closed properly and any loose items tied down safely?
- ⊙ Have you closed your leg and chest straps? Double check before you take off!

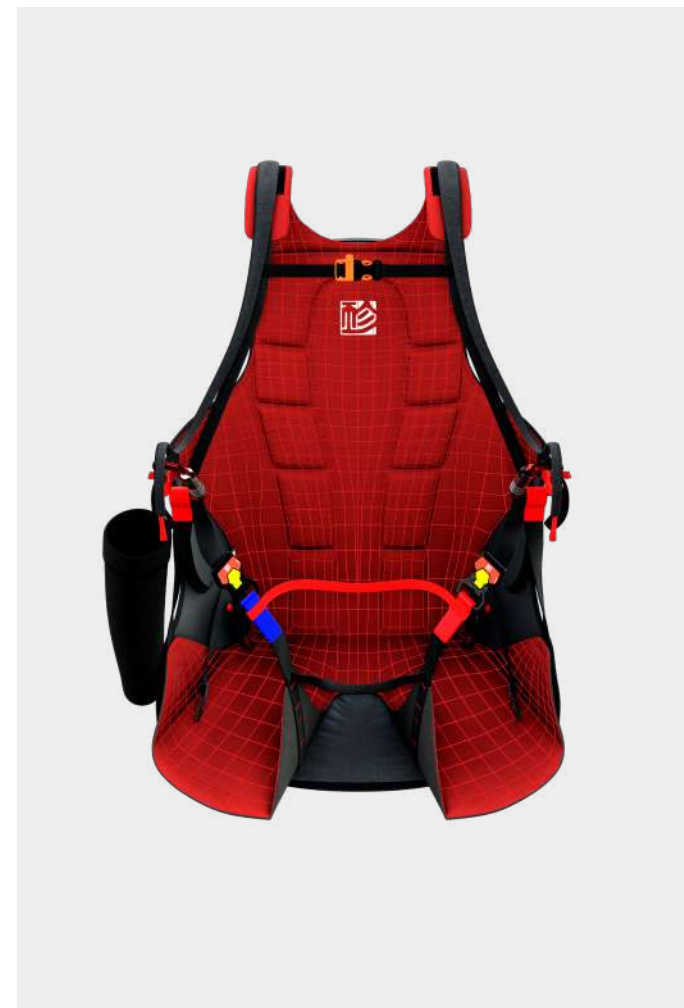

**i IMPORTANT:** Use a complete and consistent system of pre-flight checks and repeat the same sequence every flight.

**i IMPORTANT:** The maximum clip in weight of the Safari pilot 3 is 120kg, we do not recommend you fly with more than this weight.

## Rescue Deployment

In the event of an emergency, you must quickly evaluate your height and the seriousness of the incident. A seconds hesitation in deploying the reserve could prove fatal if there is insufficient height. On the other hand, deploying the rescue when the glider is recoverable may result in needless injury.

If you decide to deploy the rescue:

- 1) Look for the rescue handle and grasp it firmly with one hand
- 2) Pull forwards and upwards on the handle to release the deployment bag from the rescue container.
- 3) Look for a clear area, and in a continuous motion, throw (and RELEASE!) The rescue away from yourself and the glider, preferably into the air stream or against the direction of spin. After deployment, avoid entanglement and pendulum motions by promptly pulling in the glider as symmetrically as possible with the B, C, D or brake lines.
- 4) On landing take an upright body position and be prepared to do a PLF (Parachute Landing Fall) to minimize the risk of injury.



**i IMPORTANT:** *In normal flight, periodically feel the position of the rescue handle so that the action of reaching for the rescue handle is instinctive in an emergency.*

**! WARNING:** *During any incident in flight, always monitor your altitude. If you have any doubt that you have sufficient height for recovery, deploy your reserve without hesitation. "If in doubt, get it out!".*

**NOTE:** *After any rescue deployment, it is essential to have your harness thoroughly inspected by a qualified professional to be sure there is no damage to the rescue connection points, rescue bridle or any other parts.*



### Towing

The Safari pilot 3 can't be used for tow launches.



### Tandem Flying

The Safari pilot 3 is designed for tandem flying as a pilot harness. It must always be attached via spreader to a passenger harness.



### Flying over water

Water landings should be avoided at all costs, as the back protection increases the risk of the pilot floating in a head-down position. For safety training over water, we recommend wearing a proper flotation vest with a head support holding the wearer's head above the surface even when unconscious.

# MAINTENANCE AND REPAIRS

The materials used in this harness have been carefully selected for maximum durability. Nevertheless, keep your harness clean and airworthy to ensure the longest possible period of safe operation.

## Care and maintenance

Don't drag your harness over rough or rocky ground. Avoid unnecessary exposure to UV rays, heat and humidity. Keep the folded harness in your rucksack when not in use.

Store all your equipment in a cool, dry place, and never put it away while damp or wet. Regularly clean off dirt with a plastic bristled brush and/or a damp cloth. If the harness gets exceptionally dirty, wash it with water. Make sure you first remove the entire sub-components for example, rescue parachute etc. Allow the harness to dry naturally in a well ventilated area away from direct sunlight. If your rescue parachute ever gets wet (e.g. in a water landing) you must separate it from the harness, dry it and repack it before putting it back in its separate deployment bag.

After a hard landing you must check your harness and back protector for damage, pay close attention to the rescue container and verify all of the attachments are secure.

## Inspection checklist

The pilot should perform the following inspection on every repack of the rescue and should be checked by a professional after 24 months or 200 hours of flying, whichever comes first. Additional inspections should be performed after any crash, bad landing or take off, or if there are any signs of damage or undue wear. Always seek professional advice whenever in doubt.

**! IMPORTANT:** *Any repairs should only be carried out by the manufacturer or by an approved agent. This will ensure that the correct materials and repair techniques are used.*

**! IMPORTANT:** *No harness should ever be flown if there is any kind of damage to the webbing.*

### The following checks should be carried out:

- ⦿ Check all webbing, straps and buckles for wear and damage (e.g. open seams, tearing or cutting), especially the areas that are not easily seen, such as the inside of the carabiner hook-in points.
- ⦿ All sewing must be intact and any anomalies attended to immediately to avoid exacerbation of the problem.
- ⦿ Special attention should be paid to the rescue installation, particularly the elastic and Velcro parts.
- ⦿ The main carabiners must be replaced at least every 5 years or after 500 hours, whatever comes first. Impacts may create undetectable cracks that could result in structural failure under continuous load.
- ⦿ A careful visual inspection of the protector should be made, airbags should be filled with air and checked for leaks, moussebags and Aerobean protectors should be inspected for tears and foam recovery.

### Repairs

The manufacturer or an official GIN dealer should carry out any repair that involves critical parts of the harness. This will ensure that the correct materials and repair techniques are used.

### Storage

Store at a temperature between 10° and 25° C and in relative humidity between 50 and 75%. Make sure that the harness is not stored in a place where animals such as mice or cats could use it as a place to sleep.

Do not store the harness near any chemicals (including water). Petrol, for example, causes the material to disintegrate and can cause considerable damage to your harness. When your equipment is in the car boot, keep it as far away as possible from any spare petrol cans or oil containers.

The harness should not be exposed to extreme heat. High temperatures accelerate the process of hydrolysis, particularly when combined with moisture, which damages fibers and coating. Do not store your harness near radiators or other heat sources.



## GIN quality and service

We take pride in the quality of our products and are committed to putting right any problems affecting the safety or function of your equipment and which are attributable to manufacturing faults. Your GIN dealer is your first point of contact if you have any problems with your equipment.

If you are unable to contact your dealer or GIN importer, contact Gin Gliders directly via our website.

## GIN lifetime guarantee

Gin Gliders are proud to guarantee the quality, craftsmanship and performance of all our products. Equipment with defects in materials or manufacturing will be repaired or replaced at the discretion of Gin Gliders for the practical lifetime of the product. Equipment damaged through wear and tear, misuse or neglect may be repaired at a nominal charge.

If you have any problems with your equipment, please contact your GIN dealer in the first instance, or Gin Gliders directly via our website.

## Care of the environment

We are privileged to fly in areas of outstanding natural beauty. Respect and preserve nature by minimizing your impact on the environment. When visiting an area, contact the local club for details of environmentally sensitive areas and local restrictions.

Gin Gliders gives consideration to the entire life cycle of its harnesses, the last stage of which is recycling in an environmentally-friendly manner. The synthetic materials used in a harness must be disposed of properly. If you are not able to arrange appropriate disposal, Gin Gliders will be happy to recycle the harness for you. Send the harness with a short note to this effect to Gin Gliders Inc.

## Product registration

Register this product to receive any important safety updates.

[www.gingliders.com/register](http://www.gingliders.com/register)



## FINAL WORDS...

Most of us today live in a dependent society where we are regulated and protected. There are few opportunities for individuals to develop the self-responsibility that is the foundation of safety in extreme sports such as paragliding.

Most accidents are caused by getting into situations that are too demanding for your level of experience. This happens if you lack fundamental understanding, are incapable of assessing the risk or simply do not pay sufficient attention to your surroundings or your own state of mind.

To stay safe, the best you can do is to increase your understanding, skill and experience at a rate you can manage safely. There is no substitute for self-responsibility and good judgment.

In the end, paragliding offers a unique opportunity to learn to take control of your own destiny. Memento mori, carpe diem!



G I N

Fly safely, and...**ENJOY!**

GIN team

# TECHNICAL DATA

Size	ONE SIZE
Carabiner distance (cm)	44

## CERTIFICATION

The Safari pilot 3 is **EN** and **LTF** certified, max load 120 daN  
Certification number: **PH\_444.2024** certification

## PARACHUTE CONTAINER

Integrated container underneath the seat

## BACK PROTECTION

22cm Aerobean protector

# MATERIALS

Harness fabric	
Outer	70 D Rosetta ripstop
Inner	Nylon HD 210
Webbing	Nylon HD 210Nylon 20mm
	Polyester 30mm/25mm/20mm
Thread	100% Polyester, P/F 210D/9 bonded, P/F 210D/4 bonded & P/F 210D/6 bonded

# PILOT DETAILS / PROOF OF OWNERSHIP

## 1. Owner

Name:

Address:

Phone:

Email:

## 2. Owner

Name:

Address:

Phone:

Email:

## 3. Owner

Name:

Address:

Phone:

Email:

# HARNESSES DETAILS

Size	Colour	Serial Number
------	--------	---------------

Check flight (date):

Mark and signature:

# INSPECTIONS AND REPAIRS OVERVIEW

Date	Work carried out	General conditions on delivery	Completed by (name)	Stamp and signature

# HARNESSE DIAGRAM

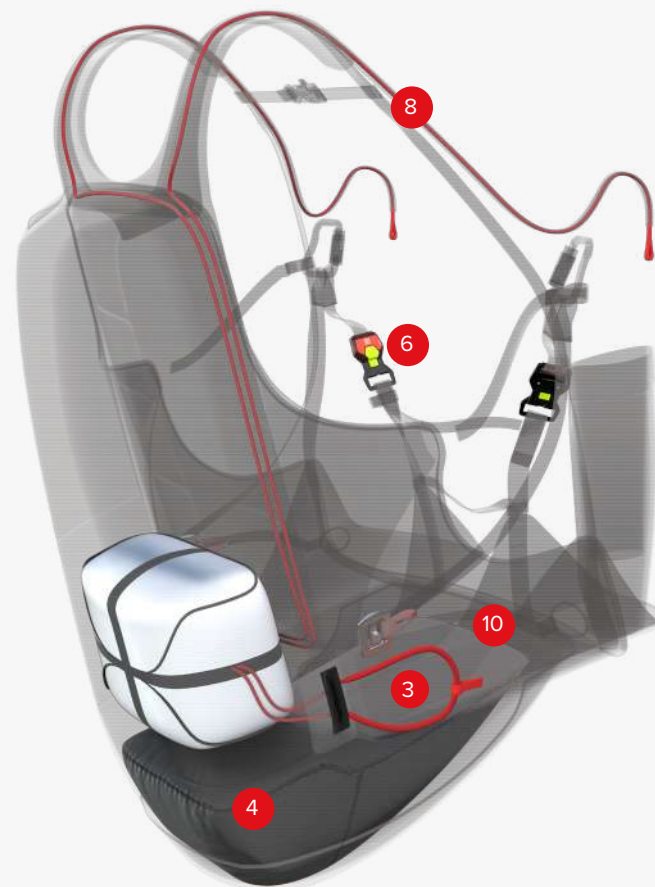

# HARNESS DIAGRAM

- |   |   |    |  |    |   |
|---|---|----|--|----|---|
| 1 | Back pocket   | 8  | Rescue bridles                                     | 15 | Color coded leg straps                    |
| 2 | Rescue container<br><i>11,000 cm<sup>3</sup> volume</i> | 9  | Gopro pocket<br><i>Removable neoprene pocket</i>   | 16 | Chest strap buckle<br><i>With whistle</i> |
| 3 | Rescue handle and innerbag                              | 10 | Adjustable hip straps                              | 17 | Spreader bars<br><i>Not included</i>      |
| 4 | Aerobean protector<br><i>22 cm thickness</i>            | 11 | Adjustable lumbar straps                           |    |   |
| 5 | Split leg geometry                                      | 12 | 30mm carabiner<br><i>Included with the harness</i> |    |   |
| 6 | Edelrid Triple lock buckles                             | 13 | Zipped side pockets<br><i>Left and right side</i>  |    |   |
| 7 | Fully covered rescue tunnel                             | 14 | Replacable protective fabric                       |    |   |



**Gin Gliders**

2318-32, Baegok-daero,  
Mohyeon-myeon, Cheoin-Gu,  
Yongin-city, Gyeonggi-Do,  
17036 Korea

[www.gingliders.com](http://www.gingliders.com)